

This 'Original instructions' document assumes that the operator carrying out any operation with this product is trained and competent to do so. This manual does not attempt to cover all details or variations in the equipment. Nor does this manual claim to provide for every possible contingency met in connection with the installation, operation, or maintenance thereof. Should further information be desired, or should a particular problem arise which is not covered in sufficient detail, the matter should be referred to Hi-Force.

OPERATING INSTRUCTION MANUAL

TWH-N SERIES | HYDRAULIC TORQUE WRENCHES - LOW PROFILE HEXAGON

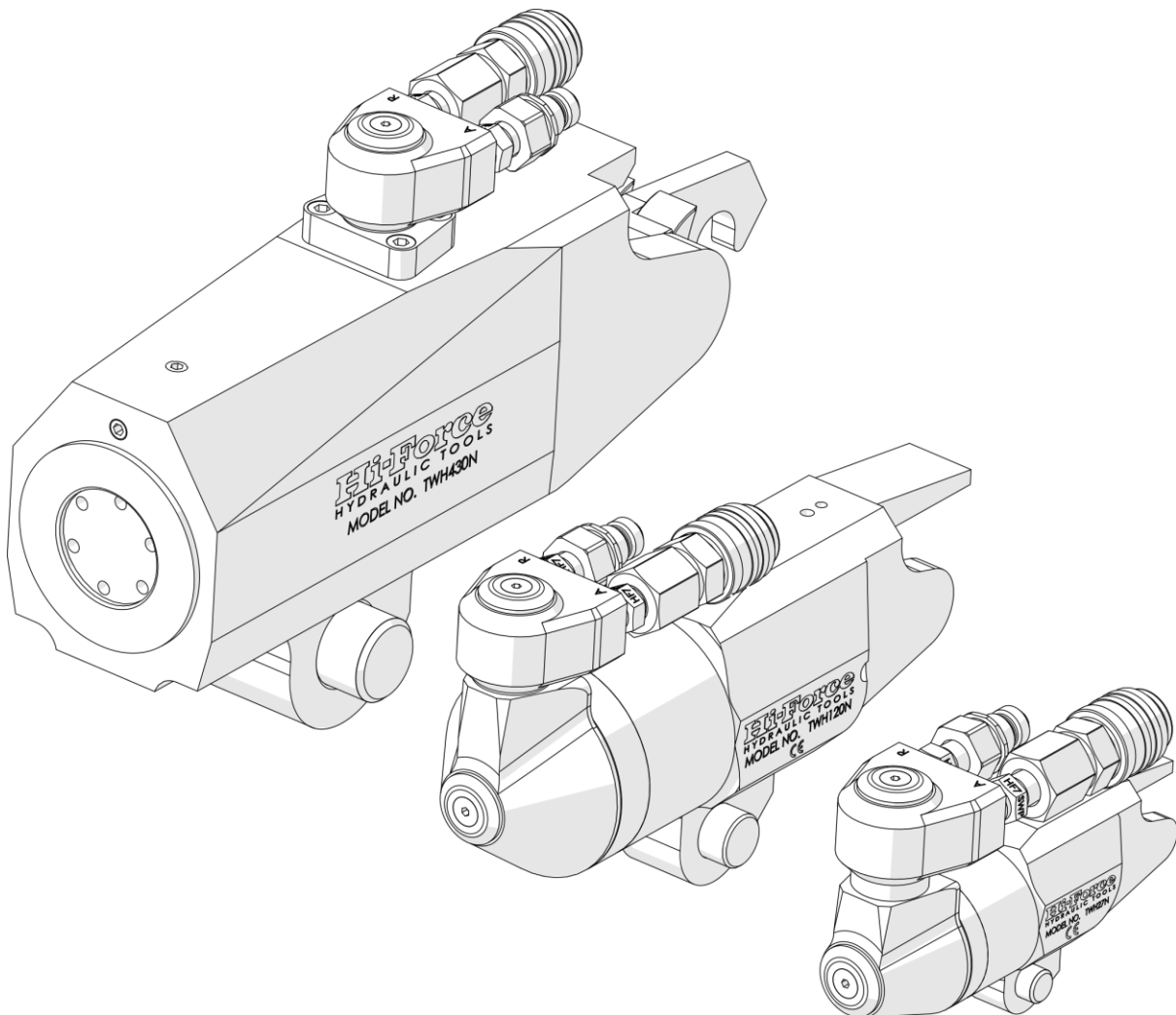

Hi-Force TWH-N series of light-weight aluminium Low Profile Hydraulic Torque Wrenches are ideally suited to bolt torquing applications with limited access. TWH-N Torque wrenches are available in torque capacities up to 48181 N·m at a maximum working pressure of 700 bar (10,000 psi). This manual applies to the Hi-Force TWH-N series Hydraulic Torque Wrenches Only. It contains the latest product information available at the time of publication and approval. Hi-Force reserves the right to make changes to this document at any time without notice.

Table of Contents

1.0 Inspection upon Receipt.....	3
2.0 Safety Precautions	3
2.1 Introduction	3
2.2 Work Area Safety	3
2.3 General Hydraulic System Safety Precautions.....	3
2.4 Hydraulic Torque Wrench Specific Safety Precautions	5
3.0 Declaration of Incorporation/Conformity	6
4.0 Component Identification	7
5.0 Installation/Setup	8
5.1 Hydraulic Connections.....	8
5.2.1 Connections (See <i>figure 5.1</i>)	9
5.2.2 Disconnections (See <i>figure 5.2</i>).....	9
5.2.3. Connecting a Torque Wrench to the Pump.....	10
5.3 Bleeding Trapped Air from the System.....	10
6.0 Operation	11
6.1 Attaching the Ratchet Head	12
6.2 Setting the Torque.....	13
6.3 Operating the Wrench	14
7.0 Maintenance and Storage.....	16
8.0 Specifications	17
8.1 Oil Specifications	17
8.2 TWH-N Specifications	17
9.0 System Components/Accessories.....	18
10.0 Torque Conversion Charts	19
11.0 Troubleshooting.....	21

TWH Model	Serial No.
TWH27N	From BK0055
TWH54N	From BC6954
TWH120N	From BC7542
TWH210N	From BC7542
TWH430N	From AZ7801 To BV7608

NOTE: Images contained within this document are for illustrative purposes **ONLY**.

1.0 Inspection upon Receipt

Upon receipt of the product, visually inspect the item for any evidence of shipping damage. Please note: the warranty does not cover shipping damage. Notify the courier immediately if shipping damage is found and refrain from putting the product into service. The carrier is responsible for repair and replacement costs resulting from damage that occurred in transit.

2.0 Safety Precautions

2.1 Introduction



Read and follow all the instructions and safety warnings carefully before handling, installation, or use of any hydraulic equipment. Failure to do so could lead to equipment damage, equipment failure, personal injury or even death. Hi-Force will not be held responsible for any damage to the equipment, injury or death resulting from the unsafe use of, lack of maintenance to, or incorrect operation of the product. If in doubt on the correct use of any Hi-Force equipment, contact your nearest Hi-Force office or distributor. Only qualified personnel should be allowed to operate hydraulic equipment. If an operator has not been trained on high-pressure hydraulic equipment and its safe usage, consult your local Hi-Force sales office or distributor who can offer training courses for operators.

2.2 Work Area Safety

- Keep work areas clean and well lit. Cluttered spaces and inadequate lighting can result in unnecessary accidents.
- Keep unauthorised persons at a safe distance from the task site.
- NEVER use tools in the presence of inflammable liquids, gases, or material.
- **DO NOT** use the tools in potentially explosive atmospheres (ATEX) this tool is **NOT** ATEX approved.

2.3 General Hydraulic System Safety Precautions



WARNING! Failure to observe and obey the following safety precautions could result in property damage, significant personal injury, or death.



- When operating any hydraulic equipment, all operators should ensure that all necessary personal protective equipment (PPE) is worn, as specified by their employer. Steel toe-cap safety shoes, safety glasses/visor and protective gloves should be always worn. All relevant risk assessments should be completed before the use of the equipment.
- Keep hydraulic equipment away from open flames and direct heat.

- **NEVER** handle a pressurised hydraulic hose. Hydraulic oil escaping under pressure from a ruptured hose can penetrate the skin and lead to a significant medical emergency, and in some cases, death. Should this incident occur, seek out medical attention immediately.
- The system operating pressure **MUST NOT** exceed the pressure rating of the lowest-rated component in the system. It is good practice to use a pressure gauge to monitor the entire system.
- Only use hydraulic tools/cylinders in a complete and tested, coupled system. **NEVER** attempt to use a tool/cylinder that is not correctly coupled to its operational pump. **NEVER** pressurise an uncoupled coupler/s.
- **NEVER** attempt to disconnect a hose from a hydraulic system until the systems pressure has been completely released. Doing so can result in that pressure becoming trapped within the system and relieving trapped pressure can be dangerous.
- **NEVER** try to relieve trapped hydraulic pressure in the system by loosening or attempting to remove the coupler. Trapped hydraulic pressure can cause a loosened coupler to dislodge unexpectedly with great force. This action could result in serious personal injury or death, as the coupler could become a projectile and hit operatives in the working area.
- Loosening a coupler under pressure can result in the escape of hydraulic oil at high pressure, which can penetrate the skin and cause significant injury or death.
- **NEVER** use a hammer and punch to unseat a coupler check valve that is under pressure. Doing so could result in the sudden, uncontrolled release of hydraulic oil at high pressure, which could cause significant injury or death.
- Immediately replace any worn or damaged parts using genuine Hi-Force parts only.
- **DO NOT** remove any labels from the product. Replace any damaged or unreadable label immediately.



CAUTION!

Failure to observe and obey the following safety precautions could result in property damage, equipment damage or minor/moderate personal injury.

- **NEVER** lift, carry, or move any hydraulic components by the hose or hoses connected to them.
- Avoid damaging hydraulic hoses. **ALWAYS** route hoses to ensure that they are free from sharp bends and kinks. Using a sharply bent or kinked hose will result in severe backpressure, which can lead to hose failure.
- **ALWAYS** operate the system under no-load conditions before the actual operation, to ensure there is no air trapped in the hydraulic circuit.
- Servicing of hydraulic equipment must only be undertaken by a qualified technician.

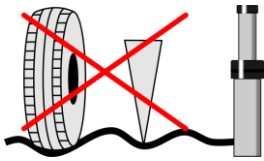

- **DO NOT** drop or place heavy objects on a hydraulic hose, as this may cause internal damage, which could result in rupture of the pressurised hose. A ruptured hose could cause significant damage to components and possible severe injury to personal operating nearby.

2.4 Hydraulic Torque Wrench Specific Safety Precautions

⚠ WARNING! Failure to observe and obey the following safety precautions could result in property damage, serious personal injury, or death.

- **NEVER** exceed the maximum rated pressure of any hydraulic equipment. Hi-Force manufactures its TWH-N hydraulic pumps to operate at a maximum working pressure of 700 bar (10,000 psi). **DO NOT** connect a pump with a higher-pressure capacity rating to any Hi-Force tool of this model series.
- **NEVER** attempt to connect or disconnect, hydraulic equipment while the system is under pressure.
- **DO NOT** weld any items to the torque wrench or modify it in any way from its delivered condition. Your warranty may be invalidated, and it could lead to serious personal injury.
- **ALWAYS** ensure there is clear communication between the pump operator and the tool operator. **DO NOT** operate the pump unless the tool operator indicates it is safe to do so.

Take extra care when multiple tools are being operated by a single pump. Make sure all tool operators have given the go-ahead before operating the pump.

- **NEVER** operate the torque wrench without both hydraulic hoses connected to it.
- This tool will exert very large reaction forces. Use proper mechanical support and correct reaction arm positioning to control these forces. **DO NOT** position the reaction arm so that it tilts the tool off the axis of the bolt and **NEVER** use the swivel coupling as a reaction point.
- **NEVER** attempt to use your hands or any other body parts as a reaction point for the tool during operation.
- This tool is **NOT ATEX RATED**. I.e., **NOT** suitable for work which takes place in explosive environments.
- When connecting hoses that have not been pre-filled with hydraulic oil, make certain the pump reservoir is not drained of oil during start-up.
- This tool is not insulated against electric shock. When using this tool with a pump that has an electrical power source or circuits, follow the pump instructions for proper grounding.

⚠ CAUTION! Failure to observe and obey the following safety precautions could result in property damage, equipment damage or minor/moderate personal injury.

- **ALWAYS** wear appropriate personal protective equipment (PPE) when carrying out maintenance on this tool.
- **ONLY** use impact sockets and accessories. **DO NOT** use hand (chrome) sockets or accessories.
- **ONLY** use Hi-Force recommended accessories.
- **ONLY** use Ratchet heads and accessories that correctly fit the nut/bolt and function without tilting the tool off the axis of the bolt.
- **DO NOT** interchange the male and female swivel inlets on the tool or the connections on one end of the hose. Reversing the inlets will reverse the power stroke cycle and may damage the tool.
- To protect your warranty, only use the hydraulic oil grade specified in Section 8.1.

3.0 Declaration of Incorporation/Conformity

Hi-Force declares that this product has been tested and complies with the standards set out in the relevant EU directives. The EU Declaration of Incorporation / Conformity is included as Annex A to this instruction document and is supplied with all shipments of this product.

4.0 Component Identification

1	Drive Cylinder	5	'Ratchet Head' Link Pin
2	Female Advance Coupler (700 bar)	6	Ratchet Head (Sold Separately)
3	Male Retract Coupler (90 bar)	7	Shroud
4	360° Uni-Swivel	-	

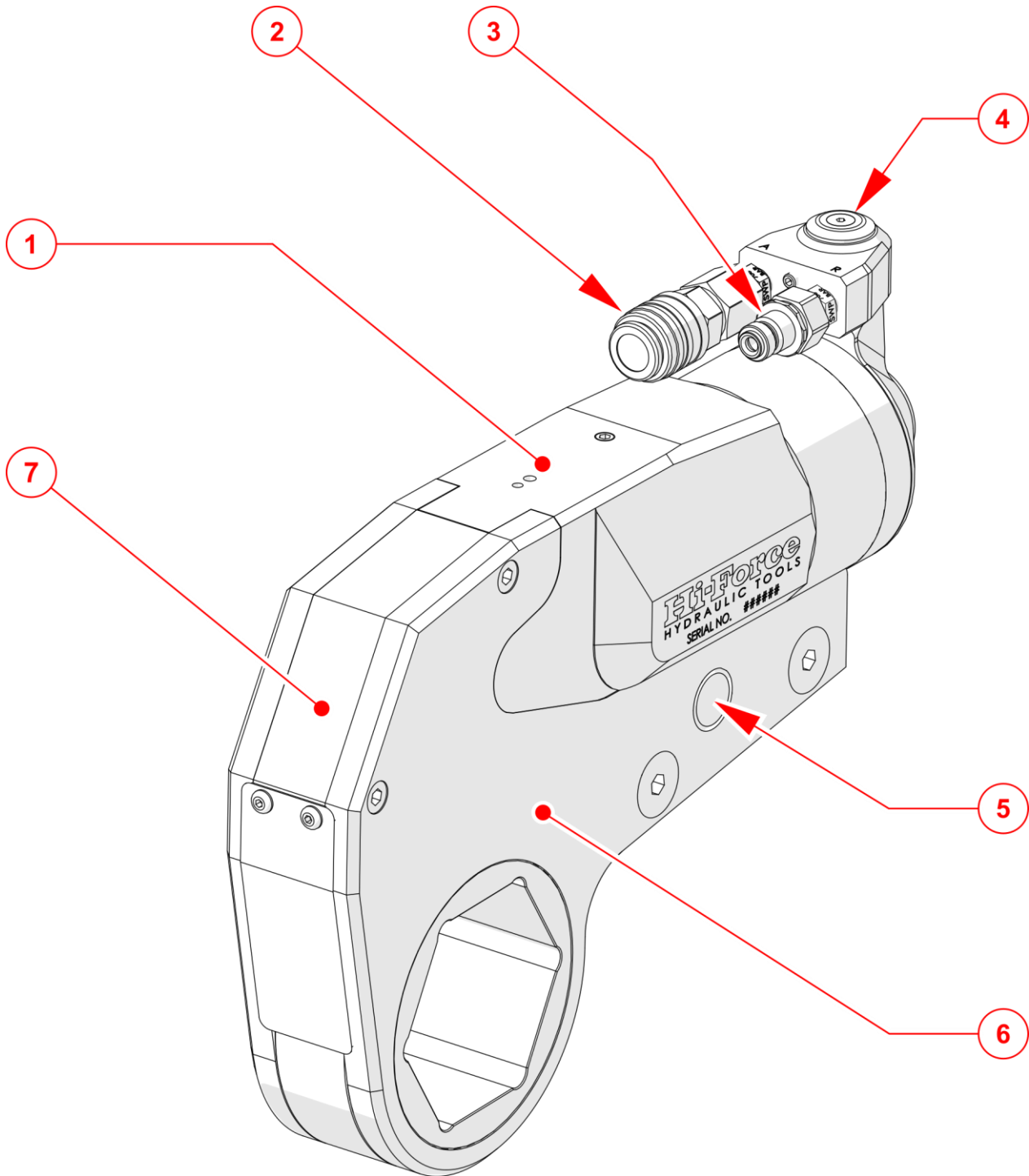

Figure 4.1: Component Identification

5.0 Installation/Setup

5.1 Hydraulic Connections

 **WARNING!**

THW-N torque wrenches are double-acting torque tools (powered in both the advance and retract directions) and **MUST** be connected to the pump via both, the advance and retract couplers. **DO NOT** pressurise the pump/system if there are any disconnected couplers in the system.

- **ALWAYS** use Hi-Force HTWH hoses to make connections.
- Hi-Force THW-N torque wrenches are fitted with dual flat-face quick-connect couplers.
- Make sure both coupler halves are clean before connecting.

 **WARNING!**

If you are **NOT** using a Hi-Force Torque Wrench pump, or if the pump or hoses have been modified, make sure that the wrench is connected correctly so that the female high-pressure advance coupler (2) is connected to the advance port on the pump. Failure to do so may result in leakage, tool damage or personal injury.

5.2.1 Connections (See figure 5.1)

Connections between couplers are made by simply [1] pressing the male coupler into the female coupler until [2] the locking collar springs forward and locks the couplers together.

⚠ WARNING! Make certain the spring-loaded retaining rings are fully engaged to prevent the connectors from disengaging under pressure. A gentle tug on the hose should be enough to make sure the hose is correctly connected.

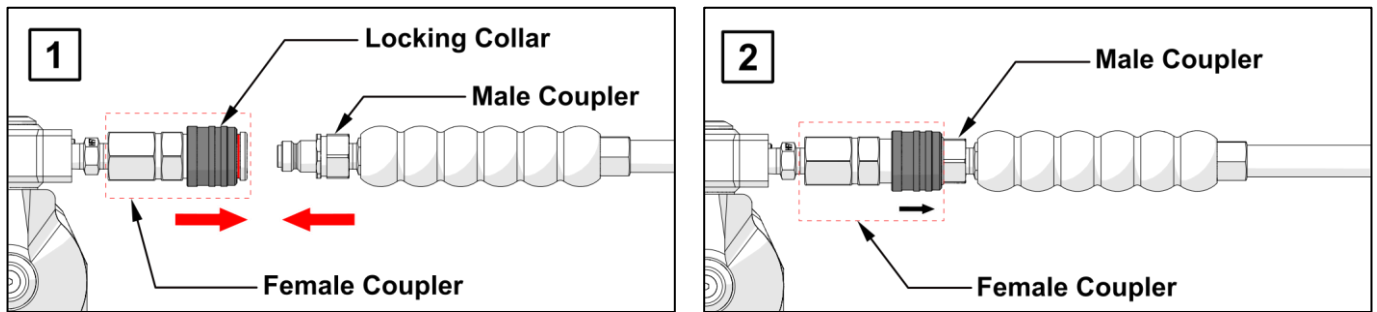

Figure 5.1: Hydraulic Connections

5.2.2 Disconnections (See figure 5.2)

⚠ WARNING! Always make sure the pump is switched off and pressure has been fully released before disconnections are made.

To disconnect couplers; [1-1] twist the locking collar on the female coupler in the direction of arrow and [1-2] pull back toward the female coupler body. [2] With the locking collar retracted, pull the male and female couplers apart. Fit dust caps after disconnections are made.

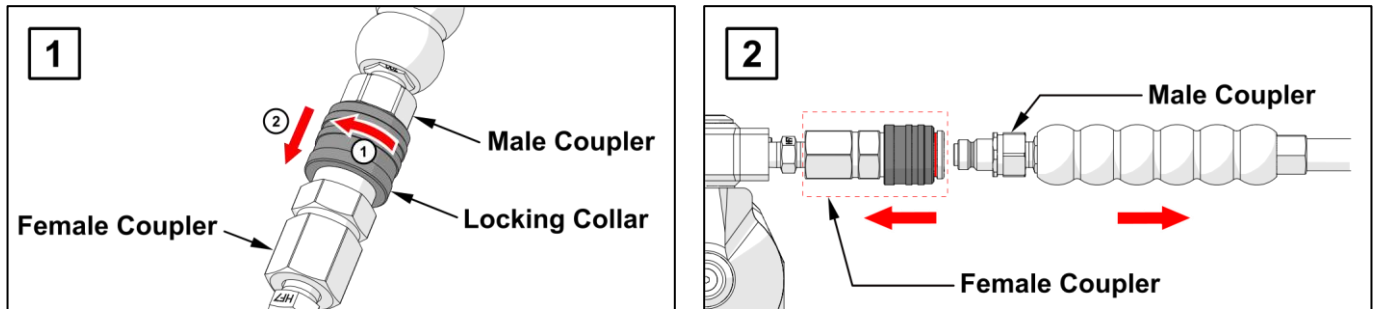

Figure 5.2: Hydraulic Disconnections

5.2.3. Connecting a Torque Wrench to the Pump

- Connect the female coupler on the red hose to the male advance coupler on the pump.
- Connect the male coupler on the black hose to the female retract coupler on the pump.

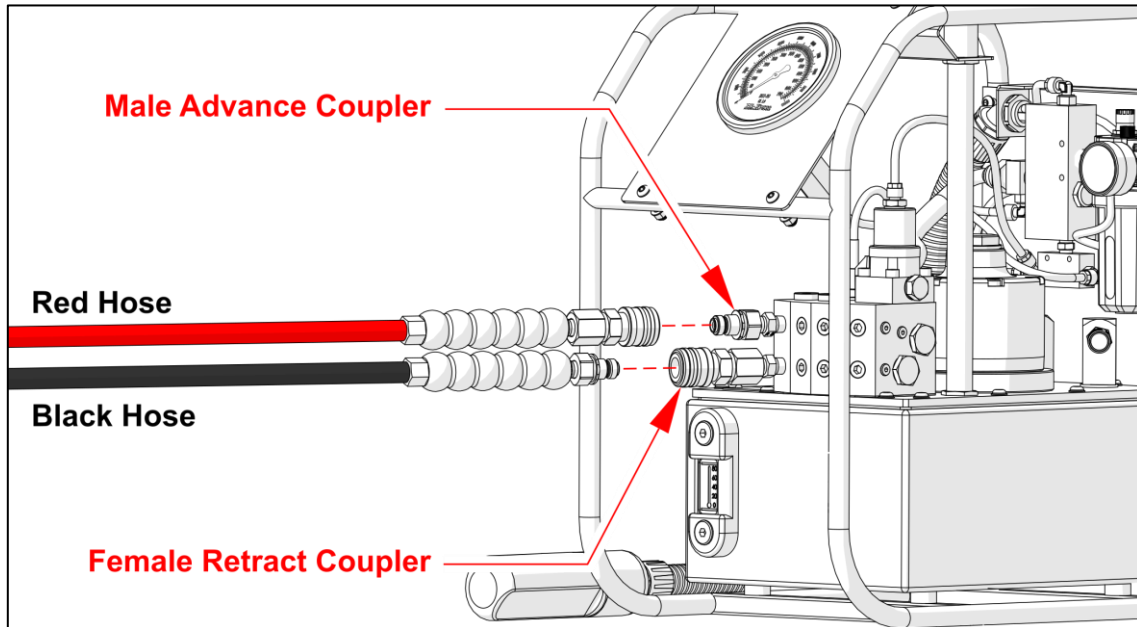

Figure 5.3: Connecting to the Pump

- Connect the free end of the red hose to the advance port on the torque wrench.
- Connect the free end of the black hose to the retract port on the torque wrench.

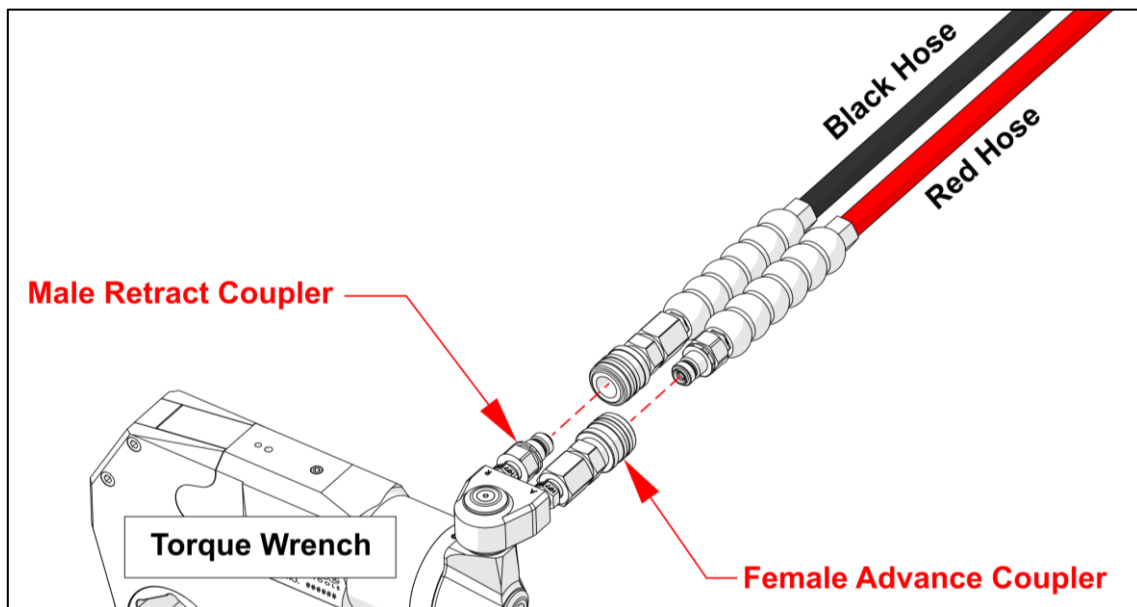

Figure 5.4: Connecting the Torque Wrench

5.3 Bleeding Trapped Air from the System

Refer to the pumps operating instructions for the correct procedure.

6.0 Operation

Hi-Force TWH-N Torque Wrenches require a suitable double-acting Hydraulic Torque Wrench pump for operation. Make sure you read this manual in conjunction with the Torque Wrench Pumps operating instruction manual to ensure correct and safe operation of all hydraulic equipment in the system.

Before applying pressure to the system make sure you observe the following points

- You are aware of the correct operation of the Torque Wrench Pump.
- You are aware of the maximum working pressure of the Torque Wrench/s.
- You are aware of the maximum torque/tension the stud/bolt can withstand.
- You are aware of the required working pressure/s that must be applied to the Torque Wrench/s.
- You have read and fully understood the torquing sequence and procedure.
- You have performed the relevant risk assessment/s and have a method statement (safe system of work) for all operators to follow.

6.1 Attaching the Ratchet Head

Before attempting to attach the ratchet head to the drive unit, make sure:

- The torque wrench piston is fully retracted (see figure 6.1). An extended piston will make the ratchet head difficult or impossible to fit.

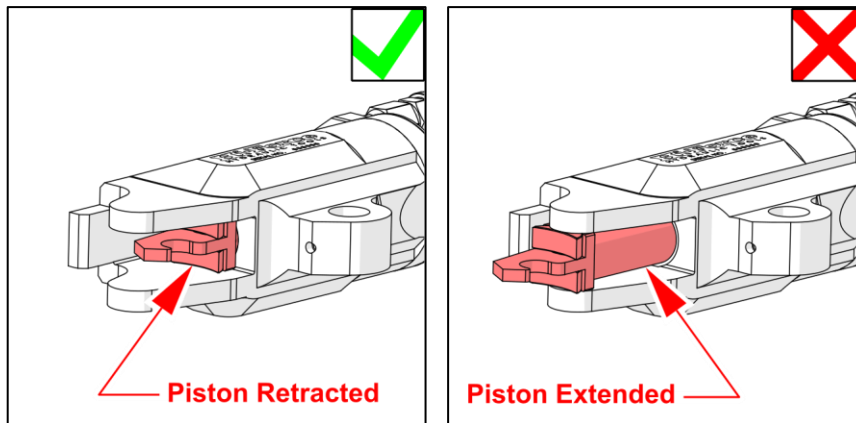

Figure 6.1: Correct Piston Position

- The ratchet head drive plate is pushed forward (see figure 6.2).

⚠ CAUTION! Failure to push the drive plate forward before connecting can result in severe damage to both the ratchet head and drive cylinder.

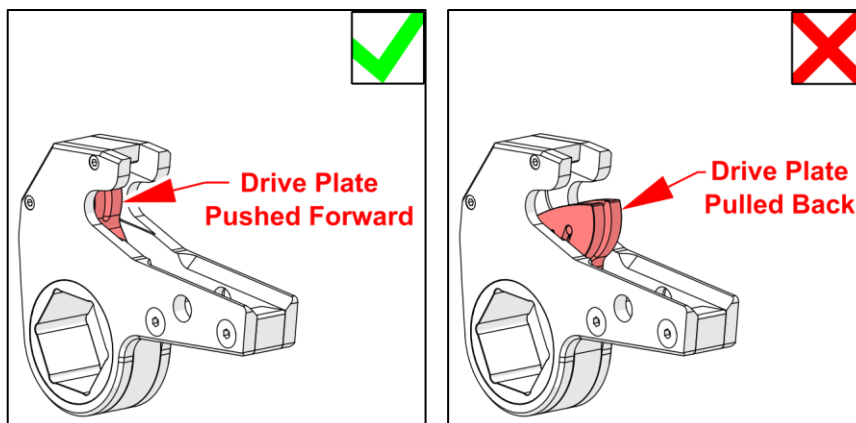

Figure 6.2: Correct Drive Plate Position

To attach the ratchet head to the drive unit:

- Make sure the piston is retracted and the drive plate is pushed forward (See Section 6.1).
- Push the Ratchet head link-pin out of the drive unit body (Newer versions are captive in the ratchet head).
- Mate the ratchet head with the drive unit as shown in figure 6.3.
- Align the 'link pin' holes in the ratchet head side plates with the hole in the drive unit and insert the pin to keep the units joined together. Make sure the link pin is properly centred between the ratchet head side plates.

NEVER operate the tool without the link pin properly fitted. This can result in tool breakage.

- Cycle the tool fully several times to check operation, before fitting on a nut.

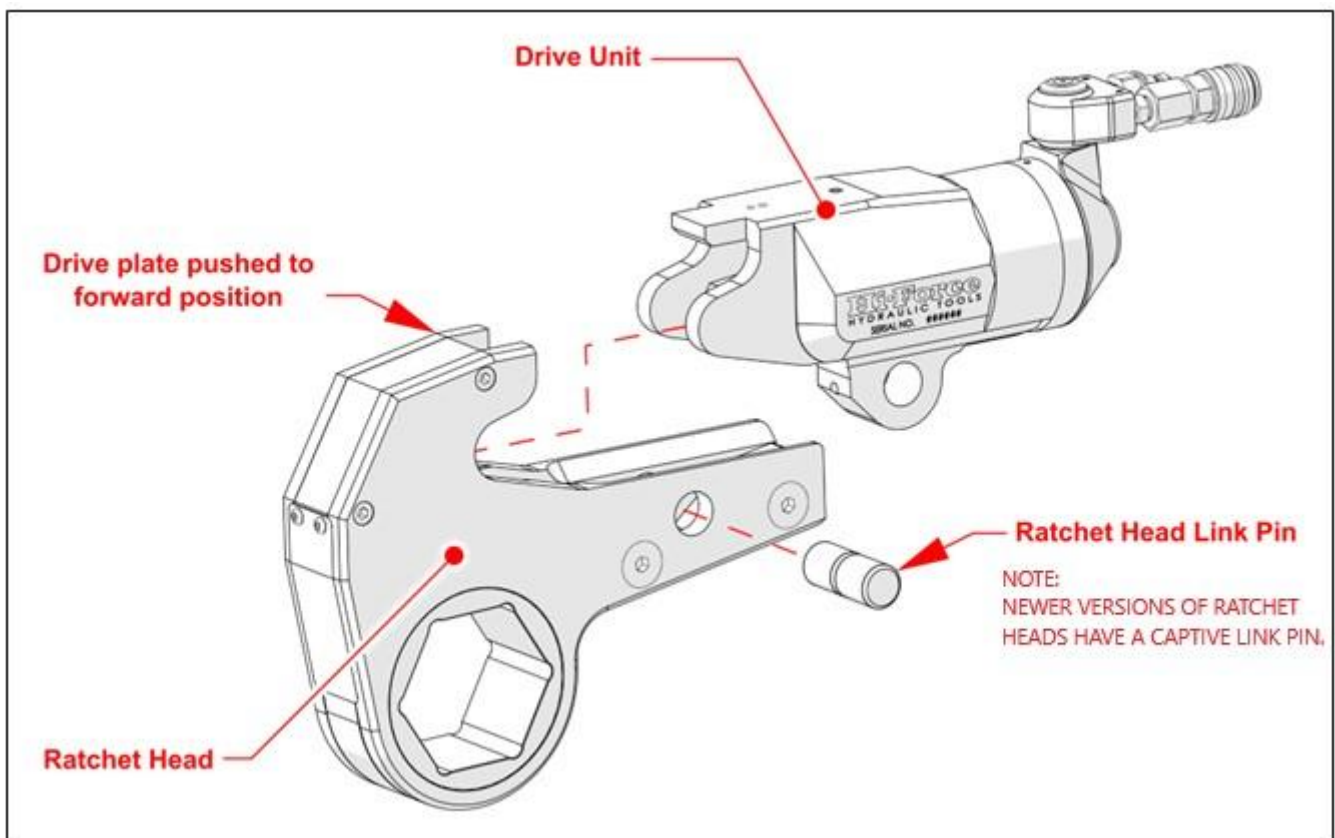

Figure 6.3: Attaching the Ratchet Head

6.2 Setting the Torque

After determining the required torque, use the torque conversion charts on pages 19 and 20 to determine the pressure necessary to achieve that torque.

Refer to the pumps operating instructions manual for a detailed procedure for setting the pumps output pressure to that determined above.

6.3 Operating the Wrench



WARNING!

Hi-force recommends that operation of the pump/wrench combination be a minimum 2-person job, one to operate the pump and one to operate the wrench. An additional operator will be required for each additional wrench connected to the pump.

To reduce the likelihood of a finger/hand trapping accident, at least one of the operators **MUST** be trained in the safe usage of the equipment and a clear system of communication **MUST** be established.

To ensure the safety of the torque tool operator/s, the pump **MUST ONLY** be operated once all torque wrench/tool operators have indicated it is safe to do so.

The position of the tool relative to the nut determines whether the action will tighten or loosen the nut. (*Refer to figure 6.4 for application examples*). The power stroke of the piston assembly will always turn the ratchet hex toward the shroud.

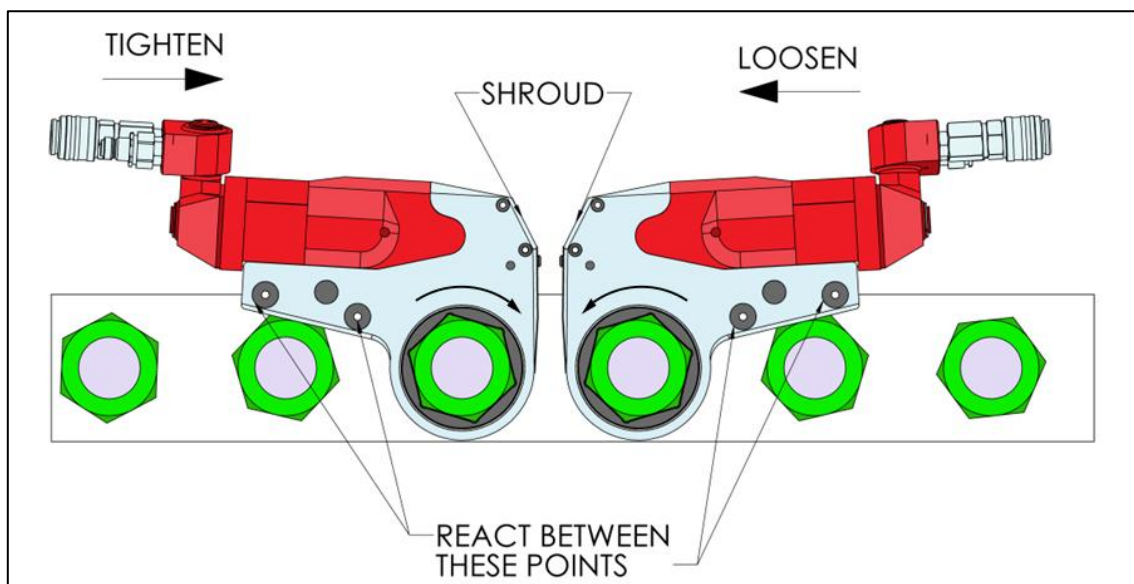

Figure 6.4: Positioning the Torque Wrench & Reaction Points

1. Place the ratchet hex on the nut/bolt to be tightened/loosened. Make certain it is the correct size for the nut/bolt and that the socket fully engages the nut/bolt.
2. Position the reaction surface against an adjacent nut, flange or other solid, system component. Make certain that there is clearance for the hoses and swivel coupling assembly.

DO NOT allow the tool to react against the hoses or swivel coupling.



WARNING!

When first placed, there will be a gap between the reaction surface and the contact point, creating a potential pinch point.

Make sure the wrench is held/supported in such a way that no body part is ever placed between the tool and the reaction surface.

3. After turning on the pump and pre-setting the pressure for the correct torque, signal the pump operator to depress the advance button on the control pendant and advance the piston assembly. (See pump manual)

NOTE: If the notch in the piston rod did not engage the retract pin in the ratchet head when the head was joined to the housing, it will engage the pin automatically during the first advance stroke.

When started, the reaction surface of the wrench or reaction arm will move against the contact point and the nut will begin to turn. Once the piston reaches the end of its stroke, the pressure will rise rapidly.

4. Retract the wrench fully.

On a pump with a '2 button' control pendant, press and hold the retract button to retract the piston. On a pump with a single button pendant, release the button to retract the tool. Under normal conditions, a series of audible clicks will be heard as the tool retracts.

5. Continue this cycling operation of advance and retract. As the nut tightens and the applied torque increases the nut rotation will slow and fewer audible clicks will be heard on retraction.
6. Continue to cycle the tool until its "stalls" (no further audible clicks will be heard on retraction) and the pre-set pressure/torque has been attained.
7. Once the nut stops rotating, cycle the tool one last time to achieve total torque.

7.0 Maintenance and Storage

Carry out basic maintenance on a regular basis to keep the torque wrench operating in a trouble-free manner. Maintenance intervals are determined by the frequency of use and the operating conditions on site.

- Keep the unit clean.
- After use, always retract the tool fully before disconnecting the attached hoses. Fit dust caps to the couplers, every time disconnections are made.
- Routinely perform a visual inspection of the tool for signs of damage.
- Store in clean and dry conditions.
- Apply lubrication as necessary.

Lubrication

Lubricant: Molybdenum Disulphide Grease

Marine Grade Moly Lube is formulated not to wash out of the tool in areas where lubrication is critical.

Lubrication frequency is dependent on factors known only to the tool user.

Whenever lubrication is required, lubricate as follows:

1. Separate the drive unit from the ratchet head if they are joined. (See figure 6.3)
2. Wipe away all the old or contaminated grease.
3. Apply grease to the hooking notch on the piston rod and wipe a film of grease onto the sides, front and back faces of the two crescent-shaped sliders on the end of the piston.

IMPORTANT: DO NOT pack the teeth of the Segment Pawl or Ratchet with lube. Doing so can prevent the teeth from engaging properly.

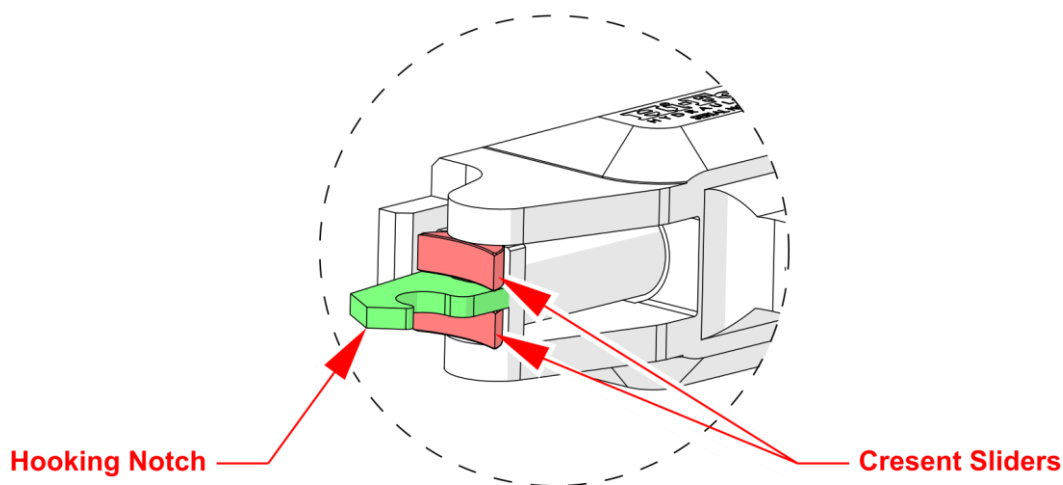

Figure 6.1: Lubrication Points

8.0 Specifications

8.1 Oil Specifications

Hi-Force tools will use 1 of 2 grades of oil, dependant on the pump used. The tools are designed to operate at temperatures between -20°C and 80°C. Details of the oil used can be found in the chosen Hi-Force pump's operating manual, in the section: **FILLING OF PUMP WITH OIL.**

Hi-Force Model Number	ISO Hydraulic Oil Grade	Temperature Range: Degrees Celcius (°C)	
		From:	To:
HFO15	ISO15	-23	44
HFO46	ISO46	-2	73

8.2 TWH-N Specifications

Refer to the engraved detail on the torque wrench body for model identification.

TWH-N Low Profile Hydraulic Torque Wrenches (Drive Unit Only)							
Model Number	Torque Capacity *		Hexagon AF Size				Weight
	Nm at 700 bar	lbf.ft at 10,000psi	Metric (mm)		Imperial (inch)		
			min	max	min	max	(kg)
TWH27N	2625	1906	24	46	1 1/16"	1 13/16"	1.4
	3068	2228	50	60	2"	2 3/8"	1.4
TWH54N	5372	3901	36	65	1 7/16"	2 9/16"	2.3
	6037	4384	70	80	2 3/4"	3 1/8"	2.3
TWH120N	11737	8522	50	80	2 3/16"	3 1/8"	3.8
	14349	10419	85	100	3 1/2"	3 7/8"	3.8
TWH210N	21216	15405	70	100	2 3/4"	3 7/8"	6.4
	23124	16791	105	115	4 1/4"	4 5/8"	6.4
TWH430N	43792	31798	80	115	3 1/8"	4 5/8"	16.1
	48181	34985	130	175	5"	6 7/8"	16.1

* Max Torque dependant on cassette AF Size.

9.0 System Components/Accessories

(Refer to the Hi-Force website or latest Hi-Force catalogue, for further details)

- HTWH Series High-Pressure Hydraulic Hoses (Up to 100m).
- HTWR1 Torque Wrench Hose Reel.
- High-Pressure Quick-Release Male and Female Half Couplers.
- TWH-NRH Metric & Imperial Hexagon AF Size Ratchet Heads.
- Square Drive Conversion Kits.
- Extended Reaction Arms.
- Removable Handle Kits.
- Metric and Imperial Hexagon Reducer Bushes.

10.0 Torque Conversion Charts

TWH-N SERIES TORQUE CONVERSION CHART (Bar/ N.m)											
Ratchet Hex Sizes	TWH27N		TWH54N		TWH120N		TWH210N		TWH430N		N.m
	1 1/16" - 1 13/16"	2" - 2 3/8"	1 7/16" - 2 9/16"	2 3/4" - 3 1/8"	2 3/16" - 3 1/8"	3 1/2" - 3 7/8"	2 3/4" - 3 7/8"	4 1/4" - 4 5/8"	3 1/8" - 4 5/8"	5" - 6 7/8"	
Pressure (Bar)	50 - 60mm		70 - 80mm		85 - 100mm		105 - 115mm		130 - 175mm		N.m
50	188	219	384	431	838	1025	1515	1652	3128	3442	
100	375	438	767	862	1677	2050	3031	3303	6256	6883	
150	563	657	1151	1294	2515	3075	4546	4955	9384	10325	
200	750	877	1535	1725	3353	4100	6062	6607	12512	13766	
250	938	1096	1919	2156	4192	5125	7577	8259	15640	17208	
300	1125	1315	2302	2587	5030	6150	9093	9910	18768	20649	
350	1313	1534	2686	3019	5869	7175	10608	11562	21896	24091	
400	1500	1753	3070	3450	6707	8199	12123	13214	25024	27532	
450	1688	1972	3453	3881	7545	9224	13639	14865	28152	30974	
500	1875	2191	3837	4312	8384	10249	15154	16517	31280	34415	
550	2063	2411	4221	4743	9222	11274	16670	18169	34408	37857	
600	2250	2630	4605	5175	10060	12299	18185	19821	37536	41298	
650	2438	2849	4988	5606	10899	13324	19701	21472	40664	44740	
700	2625	3068	5372	6037	11737	14349	21216	23124	43792	48181	

TWH-N SERIES TORQUE CONVERSION CHART (PSI/ Lbf.ft)												
Ratchet Hex Sizes	TWH27N		TWH54N		TWH120N		TWH210N		TWH430N		Pressure (PSI)	
	1 1/16" - 1 13/16"	2" - 2 3/8"	1 7/16" - 2 9/16"	2 3/4" - 3 1/8"	2 3/16" - 3 1/8"	3 1/2" - 3 7/8"	2 3/4" - 3 7/8"	4 1/4" - 4 5/8"	3 1/8" - 4 5/8"	5" - 6 7/8"		
	24 - 46mm	50 - 60mm	36 - 65mm	70 - 80mm	50 - 80mm	85 - 100mm	70 - 100mm	105 - 115mm	80 - 115mm	130 - 175mm		
	Lbf.ft	Lbf.ft	Lbf.ft	Lbf.ft	Lbf.ft	Lbf.ft	Lbf.ft	Lbf.ft	Lbf.ft	Lbf.ft	Lbf.ft	
1000	191	223	390	438	852	1042	1541	1679	3180	3499		
1500	286	334	585	658	1278	1563	2311	2519	4770	5248		
2000	381	446	780	877	1704	2084	3081	3358	6360	6997		
2500	477	557	975	1096	2131	2605	3851	4198	7950	8746		
3000	572	668	1170	1315	2557	3126	4622	5037	9539	10496		
3500	667	780	1365	1534	2983	3647	5392	5877	11129	12245		
4000	762	891	1560	1754	3409	4168	6162	6716	12719	13994		
4500	858	1003	1755	1973	3835	4689	6932	7556	14309	15743		
5000	953	1114	1951	2192	4261	5210	7703	8396	15899	17493		
5500	1048	1225	2146	2411	4687	5730	8473	9235	17489	19242		
6000	1144	1337	2341	2630	5113	6251	9243	10075	19079	20991		
6500	1239	1448	2536	2850	5539	6772	10013	10914	20669	22740		
7000	1334	1560	2731	3069	5965	7293	10784	11754	22259	24490		
7500	1430	1671	2926	3288	6392	7814	11554	12593	23849	26239		
8000	1525	1782	3121	3507	6818	8335	12324	13433	25438	27988		
8500	1620	1894	3316	3726	7244	8856	13094	14272	27028	29737		
9000	1715	2005	3511	3946	7670	9377	13865	15112	28618	31487		
9500	1811	2117	3706	4165	8096	9898	14635	15951	30208	33236		
10000	1906	2228	3901	4384	8522	10419	15405	16791	31798	34985		

11.0 Troubleshooting

Hi-Force TWH-N Low Profile Hexagon Torque Wrenches should be serviced and repaired only by authorised Hi-Force repair centres. The following table gives possible causes and solutions for common problems.

TROUBLESHOOTING GUIDE		
Problem	Possible Cause	Solution
1. Piston will not advance or retract.	a. Couplers not securely attached to the tool or pump.	Check the coupler connections and make sure they are connected correctly and fully engaged.
	b. Defective coupler.	Replace defective coupler.
	c. Defective control pendant.	See pump manual.
	d. Blockage in the directional control valve of the pump.	See pump manual.
2. Tool will not build/hold pressure.	a. Piston seal and/or end plug seal leaking.	Replace defective seals.
	b. Defective coupler.	Replace defective coupler.
	c. Sheared retaining screw/s.	Replace any damaged screws.
3. Ratchet head will not turn.	a. Lubricant or dirt build-up in the teeth of the ratchet and segment pawl.	Disassemble the ratchet and clean the grease or dirt out of the teeth.
	b. Worn or broken teeth on the ratchet and/or pawl segment.	Replace worn or damaged parts.
5. Tool will not advance.	a. Pump malfunction.	See pump manual.
	b. Oil level too low.	See pump manual.
	c. Faulty control pendant.	See pump manual.
6. Tool advances automatically, without a pendant button being pressed.	a. Tool Incorrectly connected.	Swap Hose connections at the tool.
7. Pump will only reach 80-90 bar in advance mode, but higher in retract mode.	a. Tool Incorrectly connected.	Swap Hose connections at the tool.

TROUBLESHOOTING GUIDE (continued...)

Problem	Possible Cause	Solution
8. Erratic tool movement.	a. Leakage from pump or valve internal components.	Contact your local Hi-Force office / distributor.
	b. Internal leak, due to damaged/worn seals or valves.	Contact your local Hi-Force office / distributor.
	c. Oil level too low.	See pump manual.
	d. Air in the hydraulic system.	Bleed air from the system (See pump manual)
	e. Tool piston binding.	Contact your local Hi-Force office / distributor.
9. Tool stalls under load or before maximum torque is reached.	a. Control Valve damaged.	Contact your local Hi-Force office / distributor.
	b. Seal damage/wear or internal damage.	Contact your local Hi-Force office / distributor.
10. Noisy Operation	a. Air trapped in the hydraulic system.	Bleed air from the system (See pump manual)
	b. Oil level too low.	See pump manual.

Head Office:

Hi-Force Limited

Prospect Way, Daventry

Northamptonshire NN11 8PL

United Kingdom

Tel: + 44 1327 301000 | Fax: + 44 1327 706555

www.hi-force.com

Regional Offices:

For information on our offices worldwide, scan the below QR code.

