



FLANGE TOOL INNOVATION

PRODUCT DATA SHEET

FA1TM

MECHANICAL FLANGE
ALIGNMENT TOOL

ALIGNING FORCE:
1T (10kN)

TOOL WEIGHT:
2.1kg (4.63lb)

KIT COMPONENTS

- 1 x FA1TM Tool
- 1 x Mini Ratchet Strap
- 1 x Instruction Manual

Product Code: FA1TMSTD



WEIGHTS AND DIMENSIONS

Tool Weight: 2.1kg (4.63lb)
Gross Weight: 2.3kg (5.07lb)

Box Dimensions:
180.0mm x 330.0mm x 220.0mm
(7.1" x 13.0" x 8.7")

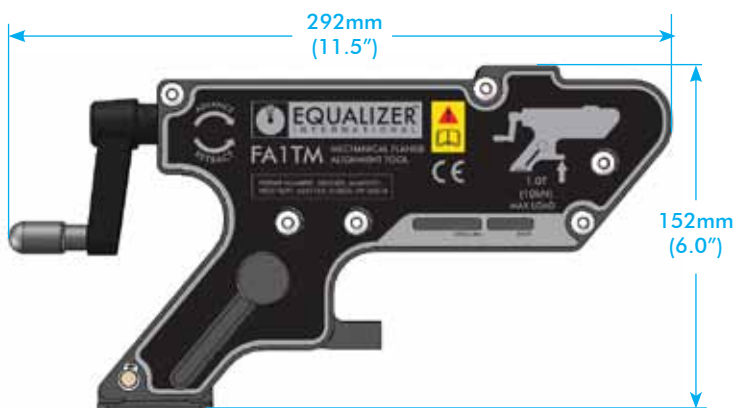

info@equalizerinternational.com
www.equalizerinternational.com

FA1™

MECHANICAL FLANGE ALIGNMENT TOOL



FLANGE TOOL INNOVATION

Minimum Extension

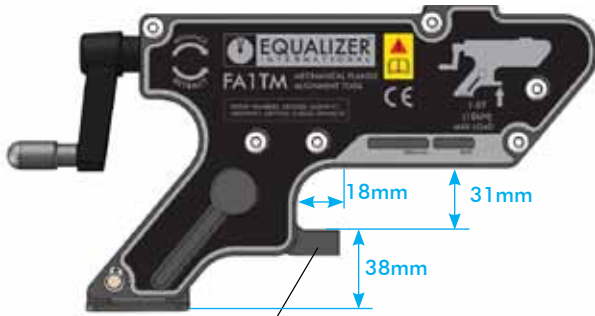

Maximum Extension

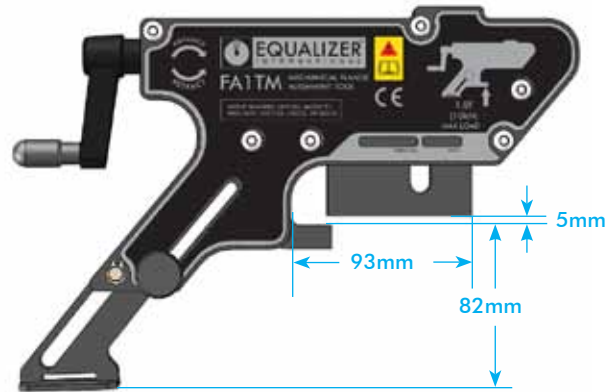

Minimum applicable Bolt Hole Diameter 16mm (0.63")

RANGE OF APPLICATION

ASME	1/2"	3/4"	1"	1 1/4"	1 1/2"	2"	2 1/2"	3"	3 1/2"	4"	5"	6"	8"	10"	12"	14"
150#						FA1™	FA1™	FA1™	FA1™	FA1™	FA1™	FA1™	FA1™	FA4™	FA4™	FA4™
300#					FA1™	FA1™	FA1™	FA1™	FA1™	FA1™	FA1™	FA1™	FA4™	FA4™	FA4™	FA4™
400#						FA1™	FA1™	FA1™	FA4™	FA4™	FA4™	FA4™	FA4™	FA4™	FA9™	FA9™
600#					FA1™	FA1™	FA1™	FA1™	FA4™	FA4™	FA4™	FA4™	FA4™	FA9™	FA9™	FA9™
900#	FA1™	FA1™	FA4™	FA4™	FA4™	FA4™	FA4™	FA4™		FA4™	FA4™	FA4™	FA9™	FA9™	FA9™	FA9™
1500#	FA1™	FA1™	FA1™	FA4™	FA4™	FA4™	FA4™	FA4™			FA9™	FA9™	FA9™	FA9™	FA9™	FA9™
2500#	FA1™	FA1™	FA4™	FA4™	FA4™	FA4™	FA4™	FA9™		FA9™	FA9™	FA9™	FA9™	FA9™	FA9™	

ASME	16"	18"	20"	24"	26"	28"	30"	32"	34"	36"	38"	40"	42"	44"	46"	48"
150#	FA4™	FA4™	FA4™	FA4™	FA4™	FA4™	FA4™	FA4™	FA4™	FA9™	FA9™	FA9™	FA9™	FA9™	FA9™	FA9™
300#	FA9™	FA9™	FA9™	FA9™	FA4™	FA4™	FA4™	FA4™	FA4™	FA4™	FA9™	FA9™	FA9™	FA9™	FA9™	FA9™
400#	FA9™	FA9™	FA9™	FA9™	FA4™	FA4™	FA4™	FA4™	FA4™	FA4™	FA9™	FA9™	FA9™	FA9™	FA9™	FA9™
600#	FA9™	FA9™	FA9™	FA9™	FA4™	FA4™	FA4™	FA4™	FA4™	FA4™	FA9™	FA9™	FA9™	FA9™	FA9™	FA9™
900#	FA9™	FA9™	FA9™	FA9™	FA9™	FA9™	FA9™									
1500#	FA9™	FA9™	FA9™													
2500#																

For other flange types, please contact Equalizer International.



FLANGE TOOL INNOVATION

PRODUCT DATA SHEET

FA4TM

MECHANICAL LINEAR AND
ROTATIONAL FLANGE
ALIGNMENT TOOL

ALIGNING FORCE:

With 68N·m (50ft·lb) of torque applied:
4T (40kN)

TOOL WEIGHT: 8.6kg (19.0lb)

KIT COMPONENTS

- 1 x FA4TM Tool
- 1 x 68N·m (50ft·lb) Torque Wrench
- 1 x 22mm Socket
- 1 x Ratchet Strap
- 1 x Instruction Manual
- 1 x Carry-Case

Product Code: FA4TMSTD



WEIGHTS AND DIMENSIONS

Tool Weight 8.6kg (19.0lb)
Case Weight 2.5kg (5.5lb)
Gross Weight 12.2kg (26.9lb)

Carry-Case Dimensions:

600 x 370 x 200mm
(23.6"x14.6"x7.9")

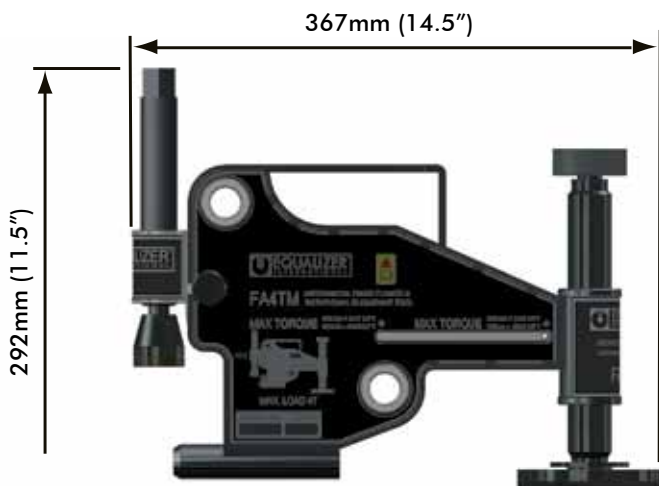

info@equalizerinternational.com
www.equalizerinternational.com

FA4™

MECHANICAL LINEAR AND ROTATIONAL
FLANGE ALIGNMENT TOOL



FLANGE TOOL INNOVATION

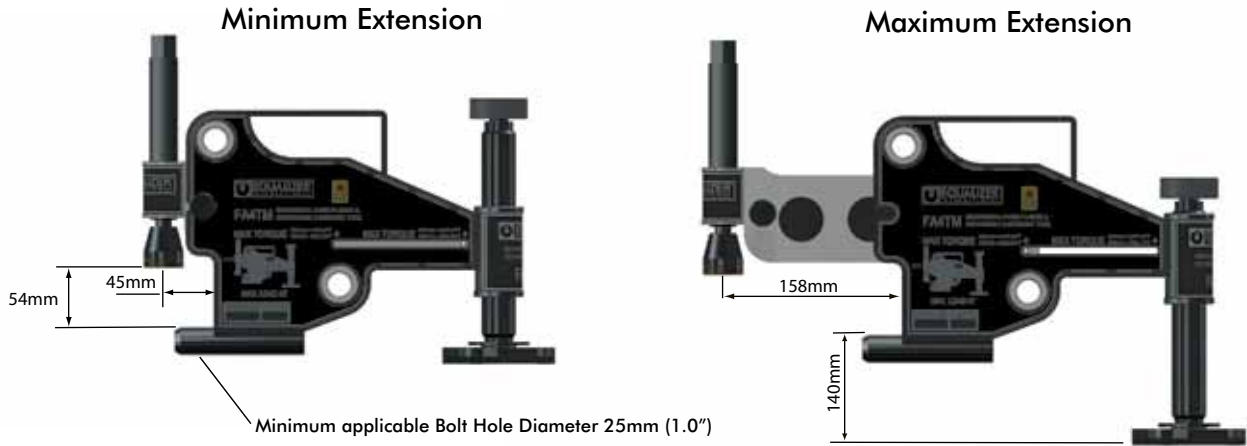

RANGE OF APPLICATION

ASME	1/2"	3/4"	1"	1 1/4"	1 1/2"	2"	2 1/2"	3"	3 1/2"	4"	5"	6"	8"	10"	12"	14"
150#						FA1TM	FA1TM	FA1TM	FA1TM	FA1TM	FA1TM	FA1TM	FA1TM	FA4TM	FA4TM	FA4TM
300#					FA1TM	FA1TM	FA1TM	FA1TM	FA1TM	FA1TM	FA1TM	FA1TM	FA4TM	FA4TM	FA4TM	FA4TM
400#						FA1TM	FA1TM	FA1TM	FA4TM	FA4TM	FA4TM	FA4TM	FA4TM	FA4TM	FA9TE	FA9TE
600#					FA1TM	FA1TM	FA1TM	FA1TM	FA4TM	FA4TM	FA4TM	FA4TM	FA4TM	FA9TE	FA9TE	FA9TE
900#	FA1TM	FA1TM	FA4TM	FA4TM	FA4TM	FA4TM	FA4TM	FA4TM		FA4TM	FA4TM	FA4TM	FA9TE	FA9TE	FA9TE	FA9TE
1500#	FA1TM	FA1TM	FA1TM	FA4TM	FA4TM	FA4TM	FA4TM	FA4TM			FA9TE	FA9TE	FA9TE	FA9TE	FA9TE	FA9TE
2500#	FA1TM	FA1TM	FA4TM	FA4TM	FA4TM	FA4TM	FA4TM	FA9TE		FA9TE	FA9TE	FA9TE	FA9TE	FA9TE	FA9TE	

ASME	16"	18"	20"	24"	26"	28"	30"	32"	34"	36"	38"	40"	42"	44"	46"	48"
150#	FA4TM	FA4TM	FA4TM	FA4TM	FA4TM	FA4TM	FA4TM	FA4TM	FA4TM	FA9TE	FA9TE	FA9TE	FA9TE	FA9TE	FA9TE	FA9TE
300#	FA9TE	FA9TE	FA9TE	FA9TE	FA4TM	FA4TM	FA4TM	FA4TM	FA4TM	FA4TM	FA9TE	FA9TE	FA9TE	FA9TE	FA9TE	FA9TE
400#	FA9TE	FA9TE	FA9TE	FA9TE	FA4TM	FA4TM	FA4TM	FA4TM	FA4TM	FA4TM	FA9TE	FA9TE	FA9TE	FA9TE	FA9TE	FA9TE
600#	FA9TE	FA9TE	FA9TE	FA9TE	FA4TM	FA4TM	FA4TM	FA4TM	FA4TM	FA4TM	FA9TE	FA9TE	FA9TE	FA9TE	FA9TE	FA9TE
900#	FA9TE	FA9TE	FA9TE	FA9TE	FA9TE	FA9TE	FA9TE									
1500#	FA9TE	FA9TE	FA9TE													
2500#																

For other flange types, please contact Equalizer International.



FLANGE TOOL INNOVATION

PRODUCT DATA SHEET

FA9TE

HYDRAULIC LINEAR AND
ROTATIONAL FLANGE
ALIGNMENT TOOL

ALIGNING FORCE:
10,000psi (700bar) 9T (90kN)

TOOL WEIGHT: 14.5kg (32.0lb)

KIT COMPONENTS

- 1 x FA9TE Tool including Hydraulic Cylinder
- 1 x 10,000 psi (700 bar) Hydraulic Hose, 2m (78.75")
- 1 x 10,000 psi (700 bar) HP350S Sealed Hand Pump with Gauge
- 1 x Instruction Manual
- 1 x Carry-Case
- 1 x Ratchet & Strap

Product Code: FA9TESTD



WEIGHTS AND DIMENSIONS

Carry-Case Dimensions
920 x 520 x 210mm
(36.2" x 20.5" x 8.3")

Tool	= 14.5kg (32.0lb)
HP350S Hand Pump	= 4.5kg (9.9lb)
Hydraulic Hose	= 1.0kg (2.2lb)
Carry-Case	= 11.0kg (24.3lb)
GROSS KIT WEIGHT	= 26.5kg (58.5lb)

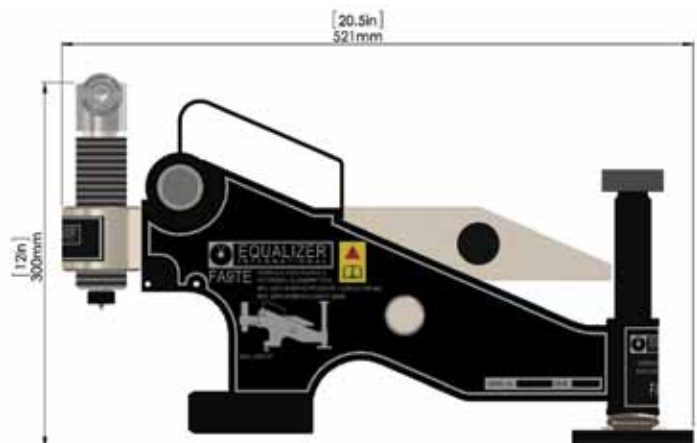

info@equalizerinternational.com
www.equalizerinternational.com

FA9TE

HYDRAULIC LINEAR AND ROTATIONAL
FLANGE ALIGNMENT TOOL



FLANGE TOOL INNOVATION

Minimum Extension

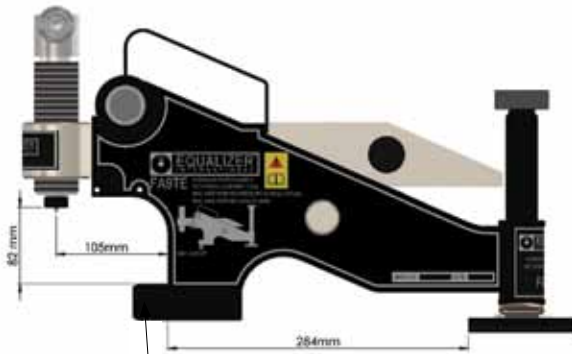

Minimum applicable bolt hole diameter 35.5mm (1.40")

Maximum Extension

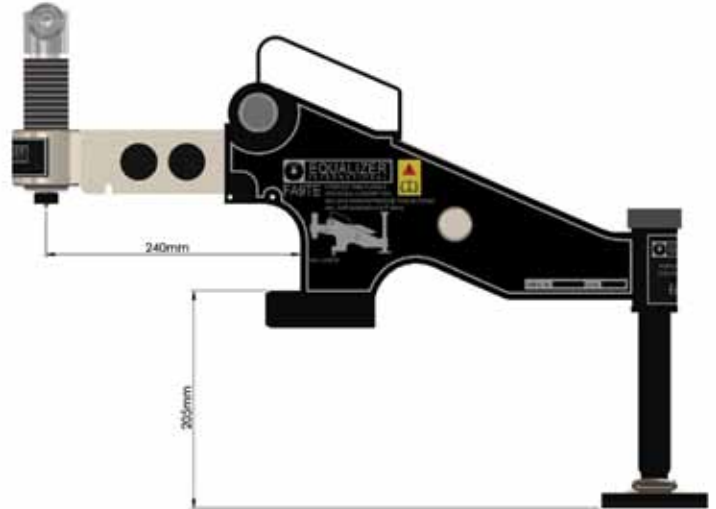

RANGE OF APPLICATION

ASME	1/2"	3/4"	1"	1 1/4"	1 1/2"	2"	2 1/2"	3"	3 1/2"	4"	5"	6"	8"	10"	12"	14"
150#						FA1TM	FA1TM	FA1TM	FA1TM	FA1TM	FA1TM	FA1TM	FA1TM	FA4TM	FA4TM	FA4TM
300#					FA1TM	FA1TM	FA1TM	FA1TM	FA1TM	FA1TM	FA1TM	FA1TM	FA4TM	FA4TM	FA4TM	FA4TM
400#						FA1TM	FA1TM	FA1TM	FA4TM	FA4TM	FA4TM	FA4TM	FA4TM	FA4TM	FA9TE	FA9TE
600#					FA1TM	FA1TM	FA1TM	FA1TM	FA4TM	FA4TM	FA4TM	FA4TM	FA4TM	FA9TE	FA9TE	FA9TE
900#	FA1TM	FA1TM	FA4TM	FA4TM	FA4TM	FA4TM	FA4TM	FA4TM		FA4TM	FA4TM	FA4TM	FA9TE	FA9TE	FA9TE	FA9TE
1500#	FA1TM	FA1TM	FA1TM	FA4TM	FA4TM	FA4TM	FA4TM	FA4TM			FA9TE	FA9TE	FA9TE	FA9TE	FA9TE	FA9TE
2500#	FA1TM	FA1TM	FA4TM	FA4TM	FA4TM	FA4TM	FA4TM	FA9TE		FA9TE	FA9TE	FA9TE	FA9TE	FA9TE	FA9TE	

ASME	16"	18"	20"	24"	26"	28"	30"	32"	34"	36"	38"	40"	42"	44"	46"	48"
150#	FA4TM	FA4TM	FA4TM	FA4TM	FA4TM	FA4TM	FA4TM	FA4TM	FA4TM	FA9TE	FA9TE	FA9TE	FA9TE	FA9TE	FA9TE	FA9TE
300#	FA9TE	FA9TE	FA9TE	FA9TE	FA4TM	FA4TM	FA4TM	FA4TM	FA4TM	FA4TM	FA9TE	FA9TE	FA9TE	FA9TE	FA9TE	FA9TE
400#	FA9TE	FA9TE	FA9TE	FA9TE	FA4TM	FA4TM	FA4TM	FA4TM	FA4TM	FA4TM	FA9TE	FA9TE	FA9TE	FA9TE	FA9TE	FA9TE
600#	FA9TE	FA9TE	FA9TE	FA9TE	FA4TM	FA4TM	FA4TM	FA4TM	FA4TM	FA4TM	FA9TE	FA9TE	FA9TE	FA9TE	FA9TE	FA9TE
900#	FA9TE	FA9TE	FA9TE	FA9TE	FA9TE	FA9TE	FA9TE									
1500#	FA9TE	FA9TE	FA9TE													
2500#																

For other flange types, please contact Equalizer International.



EQUALIZER™
INTERNATIONAL

FLANGE TOOL INNOVATION

PRODUCT DATA SHEET



TFA15TI INTEGRAL HYDRAULIC TOWER FLANGE ALIGNMENT TOOL

ALIGNING FORCE:
15T (150kN)

TOOL WEIGHT:
21.5kg (47.4lb)



KIT COMPONENTS

- 1 x TFA15TI Tool
- 1 x Instruction Manual
- 1 x Hard Case

Product Code: TFA15TISTD

REACTION FORCES

MINIMUM EXTENSION:
PARTIAL LEVERAGE

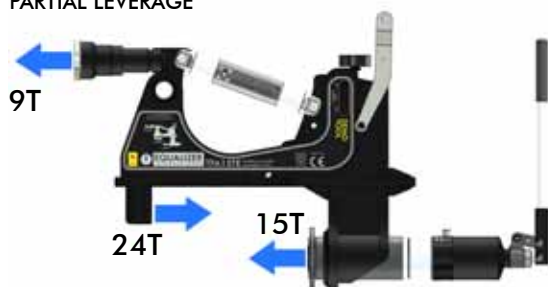

MAXIMUM EXTENSION:
FULL LEVERAGE

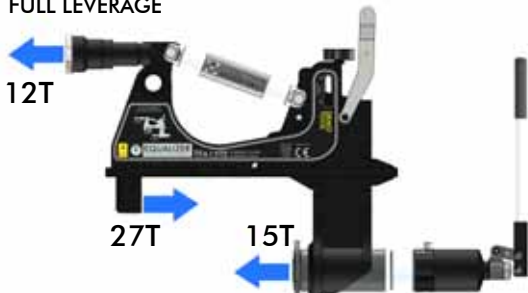

WEIGHTS AND DIMENSIONS

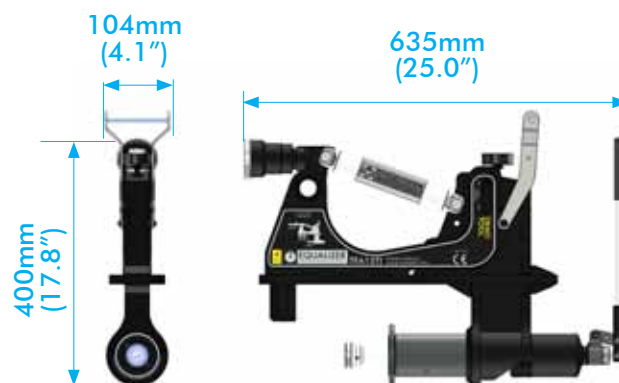

Box Dimensions:
585.0mm (23.0")
900.0mm (35.4")
170.0mm (11.8")

Tool Weight:
21.5kg (48.5lb)

Gross Kit Weight:
30.5Kg (67.2lb)

info@equalizerinternational.com
www.equalizerinternational.com

TFA15TI

INTEGRAL HYDRAULIC TOWER FLANGE ALIGNMENT TOOL



FLANGE TOOL INNOVATION

RANGE OF APPLICATION



MINIMUM EXTENSION

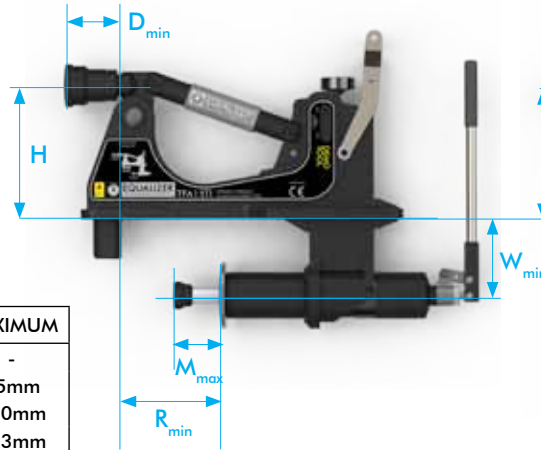

MAXIMUM EXTENSION

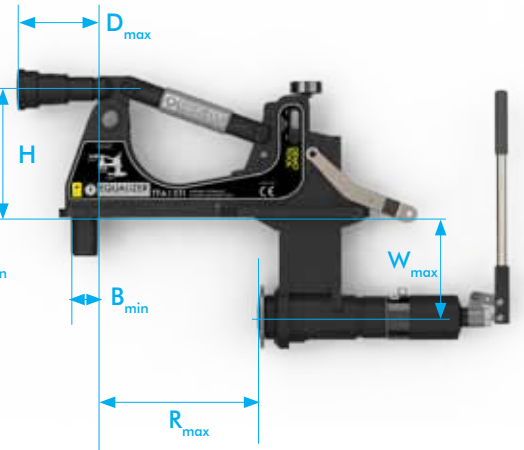

	DIMENSION	MINIMUM	MAXIMUM
B	Bolt Hole Diameter	45mm	-
M	Misalignment	0mm	65mm
R	Rise	150mm	250mm
D	Pipe Leg Drop	83mm	123mm
W	Wing Reach	120mm	163mm
H	Reaction Spacing	200mm	-

